

BLOOMFIELD

2060 Cessna Dr, Suite 100
Vacaville, CA 95688
telephone: 707-448-5151
fax: 707-448-1521
www.bloomfieldworldwide.com

OWNERS MANUAL
For

611

Koffee-KingTM

MODULAR
BREWING SYSTEMS

MODELS

POUR OVER
UNITS

8542
8543
8571

AUTOMATIC
UNITS

8573

AUTOMATIC
UNITS
WITH FAUCET

8540
8572

Includes:

Installation
Use & Care
Servicing Instructions



Model 8572 Brewer
with optional
8900-Series Glass Decanters

WARRANTY STATEMENT

All electrical equipment manufactured by BLOOMFIELD is warranted against defects in materials and workmanship for a period of **(1 year labor, two year parts)** from the date of original installation and is for the benefit of the original purchaser, except that:

- a. airpots carry a 30 day parts warranty only.
- b. dispensers; i.e., tea and coffee carry a 90 days parts warranty only, excludes decanters.
- c. decanters are not covered by this warranty

THE FOREGOING OBLIGATION IS EXPRESSLY GIVEN IN LIEU OF ANY OTHER WARRANTIES, EXPRESSED OR IMPLIED, INCLUDING ANY IMPLIED WARRANTY OF MERCHANTABILITY OR FITNESS FOR A PARTICULAR PURPOSE, WHICH ARE HEREBY EXCLUDED.

BLOOMFIELD, LLC SHALL NOT BE LIABLE FOR INDIRECT, INCIDENTAL OR CONSEQUENTIAL DAMAGES OR LOSSES FROM ANY CAUSE WHATSOEVER.

This warranty is void if it is determined that upon inspection by an authorized service agency that the equipment has been modified, misused, misapplied, improperly installed, or damaged in transit or by fire, flood or act of God.

It also does not apply if the serial nameplate has been

removed or unauthorized service personnel perform service. The prices charged by Bloomfield for its products are based upon the limitations in this warranty. Seller's obligation under this warranty is limited to the repair of defects without charge by a Bloomfield Authorized Service Agency or one of its sub-agencies. This service will be provided on customer's premises for non-portable models. Portable models (a device with a cord and plug of a dispenser) must be taken or shipped to the closest authorized service agency, transportation charges prepaid, for services.

In addition to restrictions contained in this warranty, specific limitations are shown below (Additional Warranty Exclusions). Bloomfield Authorized Service Agencies are located in principal cities.

This warranty is valid in the United States, Canada and void elsewhere. Please consult your classified telephone directory or your food service equipment dealer; or, for information and other details concerning warranty, write to:

PARTS TOWN
1200 Greenbriar Dr,
Addison, IL 60101

Phone: (800) 438-8898 Fax: (888) 513-0259
customerservice@partstown.com / www.bloomfieldworldwide.com

SERVICE POLICY AND PROCEDURE GUIDE ADDITIONAL WARRANTY EXCLUSIONS

1. Resetting of safety thermostats, circuit breakers, overload protectors, or fuse replacements.
2. All problems due to operation at voltages other than specified on equipment nameplates - conversion to correct voltage must be the customer's responsibility.
3. All problems due to electrical connections not made in accordance with electrical code requirements and wiring diagrams supplied with the equipment.
4. Replacement of items subject to normal wear, to include such items as knobs and light bulbs. Normal maintenance functions including adjustment of thermostats, microswitches, and replacement of fuses and indicating lights are not covered under warranty.
5. All problems due to inadequate water supply, such as fluctuating, or high or low water pressure.
6. All problems due to mineral/calcium deposits, or contamination from chlorides/chlorines. De-liming is considered a preventative maintenance function and is not covered by warranty.
7. Full use, care and manuals may or may not be sent with each unit, only a condensed version. Please visit our web site to download the full version.
8. Travel mileage is limited to fifty (50) miles from an authorized service agency or one of its sub-service agencies.
9. All labor shall be performed during normal working hours. Overtime premium shall be charged to the customer.
10. All genuine Bloomfield replacement parts are warranted for ninety (90) days from date of purchase on non-warranted equipment. **Any use of non-genuine Bloomfield parts completely voids any warranty.**
11. Installation, labor and job checkouts are not considered warranty.
12. Charges incurred by delays, waiting time or operating restrictions that hinder the service technicians ability to perform services are not covered by warranty. This includes institutional and correctional facilities.

SHIPPING DAMAGE CLAIMS PROCEDURE

NOTE: For your protection, please note that equipment in this shipment was carefully inspected and packaged by skilled personnel before leaving the factory. Upon acceptance of this shipment, the transportation company assumes full responsibility for its safe delivery.

IF SHIPMENT ARRIVES DAMAGED:

1. **VISIBLE LOSS OR DAMAGE:** Be certain that any visible loss or damage is noted on the freight bill or express receipt, and that the note of loss or damage is signed by the delivery person.
2. **FILE CLAIM FOR DAMAGE IMMEDIATELY:** Regardless of the extent of the damage.

3. **CONCEALED LOSS OR DAMAGE:** if damage is unnoticed until the merchandise is unpacked, notify the transportation company or carrier immediately, and file "CONCEALED DAMAGE" claim with them. This must be done within fifteen (15) days from the date the delivery was made to you. Be sure to retain the container for inspection.

Bloomfield cannot assume liability for damage or loss incurred in transit. We will, however, at your request, supply you with the necessary documents to support your claim.

TABLE OF CONTENTS

WARRANTY STATEMENT	xi
SPECIFICATIONS	1
FEATURES & OPERATING CONTROLS	2
PRECAUTIONS & GENERAL INFORMATION	3
AGENCY APPROVAL INFORMATION	3
INSTALLATION INSTRUCTIONS	4
OPERATION	6
BREWING COFFEE	8
CLEANING INSTRUCTIONS	9
TROUBLESHOOTING SUGGESTIONS	10
SERVICING INSTRUCTIONS	11
Deliming Instructions	16
EXPLODED VIEWS & PARTS LISTS	18
WIRING DIAGRAMS	22

Thank You for purchasing this Bloomfield appliance.

Proper installation, professional operation and consistent maintenance of this appliance will ensure that it gives you the very best performance and a long, economical service life.

This manual contains the information needed to properly install this appliance, and to use, care for and maintain or repair the appliance in a manner which will ensure its optimum performance.

SPECIFICATIONS

Country	Bloomfield Model	Type	Warmers	Faucet	Volts	Amps	Watts	Power Supply Cord
USA	4A-8540D2F-120V	In-Line Automatic, Plumbed-In	2	Yes	120	14.1	1700	NEMA 5-15P
	4B-8542-D1-120V	In-Line, Pour-Over	1	No	120	13.3	1600	NEMA 5-15P
	4B-8543-D2-120V	In-Line, Pour-Over	2	No	120	14.1	1700	NEMA 5-15P
	4B-8571-D3-120V	3-Station, Pour-Over	3	No	120	15	1800	NEMA 5-15P
	4A-8572D3F-120V	3-Station, Automatic, Plumbed-In	3	Yes	120	15	1800	NEMA 5-15P
	4A-8572-D3-120V	3-Station, Automatic, Plumbed-In	3	No	120	15	1800	NEMA 5-15P
	4A-8573D3-120V	3-Station, Automatic, Plumbed-In	3	No	120	15	1800	NEMA 5-15P
CANADA	4A-8540D2F-120C	In-Line Automatic, Plumbed-In	2	Yes	120	11.7	1500	NEMA 5-15P
	4B-8542-D1-120C	In-Line, Pour-Over	1	No	120	10.8	1400	NEMA 5-15P
	4B-8543-D2-120C	In-Line, Pour-Over	2	No	120	11.7	1500	NEMA 5-15P
	4B-8571-D3-120C	3-Station, Pour-Over	3	No	120	12.5	1500	NEMA 5-20P
	4A-8572D3F-120C	3-Station, Automatic, Plumbed-In	3	Yes	120	12.5	1500	NEMA 5-20P
	4A-8573D3-120C	3-Station, Automatic, Plumbed-In	3	No	120	15	1800	NEMA 5-20P

FEATURES AND OPERATING CONTROLS

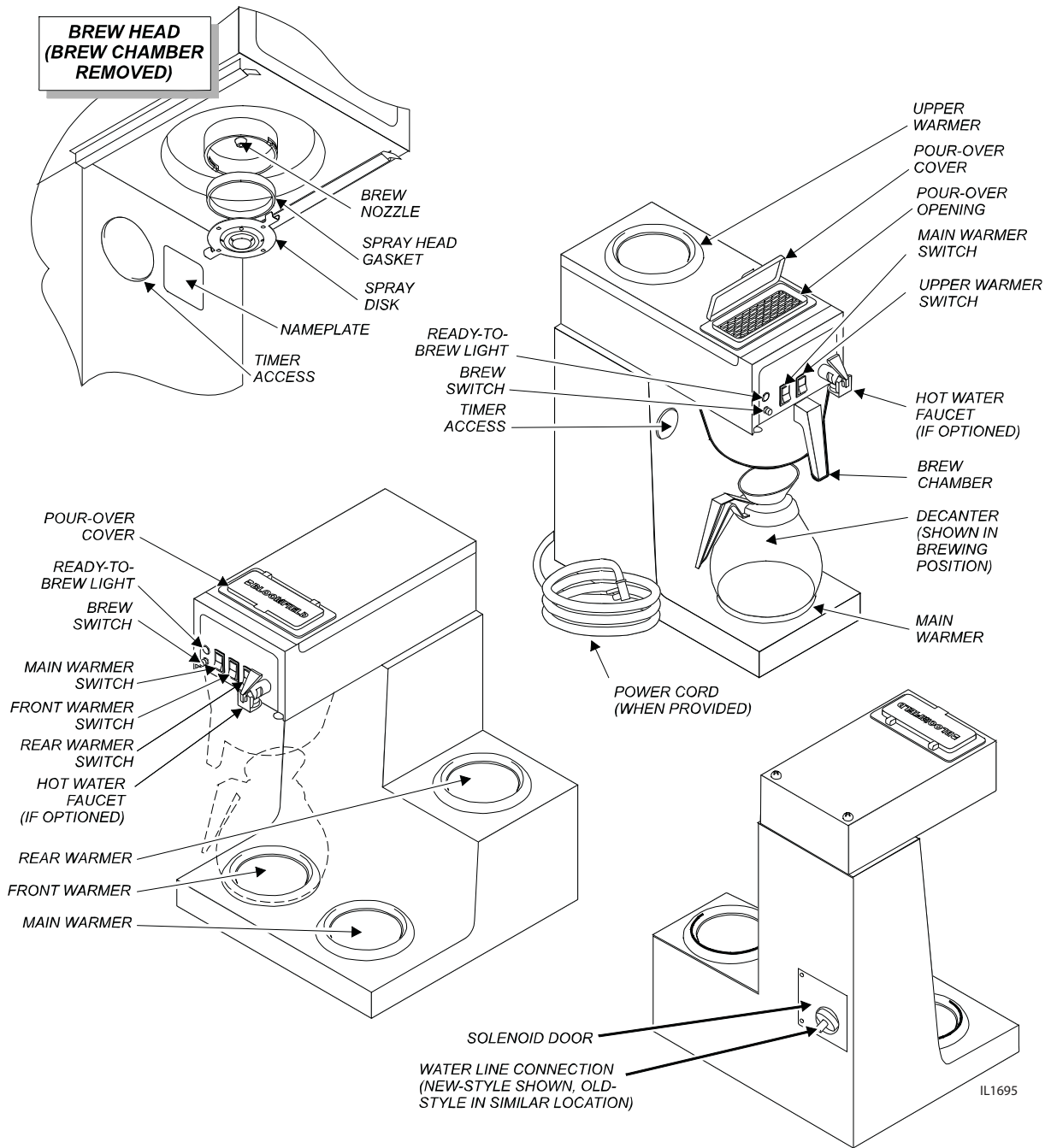

Fig. 1 Features & Operating Controls

PRECAUTIONS AND GENERAL INFORMATION



WARNING: ELECTRIC SHOCK HAZARD

All servicing requiring access to non-insulated components must be performed by qualified service personnel. Do not open any access panels which require the use of tools. Failure to heed this warning can result in electrical shock.



WARNING: INJURY HAZARD

All installation procedures must be performed by qualified personnel with full knowledge of all applicable electrical and plumbing codes. Failure could result in property damage and personal injury.



WARNING: ELECTRIC SHOCK HAZARD

Brewer must be properly grounded to prevent possible shock hazard. DO NOT assume a plumbing line will provide such a ground. Electrical shock will cause death or serious injury.



WARNING: BURN HAZARD

This appliance dispenses very hot liquid. Serious bodily injury from scalding can occur from contact with dispensed liquids.

This appliance is intended for commercial use only.

This appliance is intended for use to brew beverage products for human consumption. No other use is recommended or authorized by the manufacturer or its agents.

This appliance is intended for use in commercial establishments, where all operators are familiar with the appliance use, limitations and associated hazards. Operating instructions and warnings must be read and understood by all operators and users.

Except as noted, this piece of equipment is made in the USA and has American sizes on hardware. All metric conversions are approximate and can vary in size.

The following trouble shooting, component views and parts lists are included for general reference, and are intended for use by qualified service personnel.

This manual should be considered a permanent part of this appliance. The manual must remain with the appliance if it is sold or moved to another location.



CAUTION: EQUIPMENT DAMAGE

DO NOT plug in or energize this appliance until all *Installation Instructions* are read and followed. Damage to the Brewer will occur if these instructions are not followed.



CAUTION: BURN HAZARD

Exposed surfaces of the appliance, brew chamber and decanter may be HOT to the touch, and can cause serious burns.

AGENCY APPROVAL INFORMATION

These brewers are  listed under ETL 3016449.

This brewer meets  Standard 4 only when installed, operated and maintained in accordance with the enclosed instructions.



INSTALLATION INSTRUCTIONS

READ THIS CAREFULLY BEFORE STARTING THE INSTALLATION

IMPORTANT:

To enable the installer to make a quality installation and to minimize installation time, the following suggestions and tests should be done before the actual unit installation is started:



CAUTION: EQUIPMENT DAMAGE

DO NOT plug in or energize this appliance until all Installation Instructions are read and followed. Damage to the Brewer will occur if these instructions are not followed.



CAUTION: UNSTABLE EQUIPMENT HAZARD

It is very important for safety and for proper operation that the brewer is level and stable when standing in its final operating position. Provided adjustable, non-skid legs must be installed at each corner of the unit. Failure to do so will result in movement of the brewer which can cause personal injury and/or damage to brewer.

NOTE: Water supply inlet line must meet certain minimum criteria to insure successful operation of the brewer. Bloomfield recommends 1/4" copper tubing for installation of less than 25 feet and 3/8" for more than 25 feet from a 1/2" water supply line.

REFER TO EXPLODED VIEWS PAGES 18 thru 22 FOR COMPONENT NAMES/NUMBERS

Unpack the unit. Inspect all components for completeness and condition. Ensure that all packing materials have been removed from the unit.

Verify that the Spray Head Gasket (#33) and Spray Disk (#34) are properly installed.

LEVELING THE UNIT

Verify that an adjustable leg is installed at each corner of the brewer.

Set Brewer in its operating location. Level the Brewer. A spirit level should be placed on the top of the unit, at the edge, as a guide when making level adjustments.

Level the unit from left to right and front to back by turning the adjustable feet. Be sure all four feet touch the counter to prevent tipping.

PLUMBER'S INSTALLATION INSTRUCTIONS

Brewer should be connected to a **POTABLE WATER, COLD WATER** line. Flush water line before connecting to Brewer.

DO NOT use a saddle valve with a self-piercing tap for the water line connection. Such a tap can become restricted by waterline debris. For systems that must use a saddle tap, shut off the main water supply and drill a 3/16" (minimum) tap for the saddle connection, in order to insure an ample water supply. Remember to flush the line prior to installing the saddle.

The brewer must be installed on a water line with average pressure between 20 PSI and 90 PSI. If your water pressure exceeds 90 PSI at anytime, a pressure regulator must be installed in the water supply line to limit the pressure to not more than 90 PSI in order to avoid damage to lines and solenoid.

A water shut-off valve should be installed on the incoming water line in a convenient location (Use a low restriction type valve, such as a 1/4-turn ball valve, to avoid loss of water flow thru the valve.

The provided water line strainer must be installed in the supply line, between the shutoff valve and inlet fitting. Note FLOW arrow marking on strainer body.

INSTALLATION INSTRUCTIONS (continued)

NSF requires that the brewer be able to be moved for cleaning underneath. A flex line or loops of copper tubing will satisfy this requirement. See Figure 2 below.

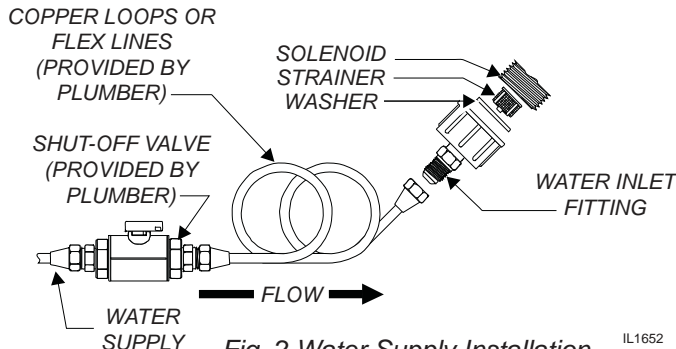

Fig. 2 Water Supply Installation
New-style shown

IL1652

In some areas, local codes require a backflow preventer (check valve) to be installed on the inlet water line. If a backflow preventer is used, you must install a **water hammer arrester** in the incoming line, between the backflow preventer and the brewer inlet, as far away from the brewer as space will allow. This will relieve the excessive back pressures that can cause faucet leaks and solenoid malfunctions.

ELECTRICIAN'S INSTALLATION INSTRUCTIONS

REFER TO ELECTRICAL SPECIFICATIONS - Page 1

Check the nameplate to determine correct electrical service required for the Brewer to be installed.

IMPORTANT: Before connecting to electricity, make sure automatic brewers are connected to the water supply.

All models are equipped with a cord and plug. They require a 115 - 125 volt 20 amp circuit (50/60 Hz, 2 wire plus ground, with NEMA 5-15R or 5-20R Receptacle).

IMPORTANT: The ground prong of the plug is part of a system designed to protect you from electrical shock in the event of internal damage. Never cut off the ground prong nor twist a blade to fit an existing receptacle. Contact a licensed electrician to install the proper circuit and receptacle.

NOTE: This equipment must be installed to comply with applicable federal, state and local plumbing codes and ordinances.



WARNING: SHOCK HAZARD

Brewer must be properly grounded to prevent possible shock hazard. **DO NOT** assume a plumbing line will provide such a ground. Electrical shock will cause death or serious injury.

IMPORTANT: Do not connect brewer to electrical power until the tank is filled with water. Pour water into the pour-over opening until water flows from the brew head.

IMPORTANT:

Supply power must match nameplate for voltage and phase. Connecting to the wrong voltage will damage the brewer or result in decreased performance. Such damage is not covered by warranty.

OPERATION

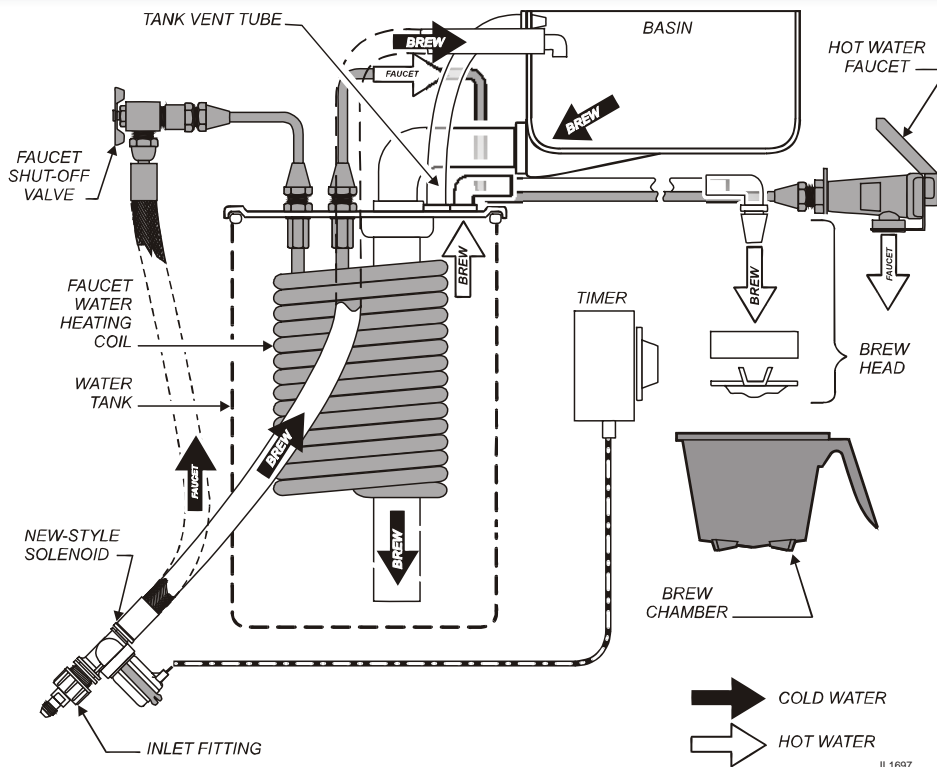
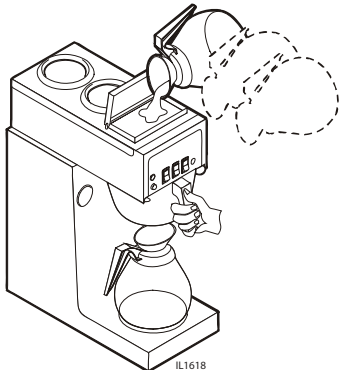

Fig. 4 Brewer Operation Diagram

IMPORTANT:

Tank must be full of water before connecting brewer to electrical power. Heating elements will be damaged if allowed to operate without being fully submerged in water. Damage caused by operating the brewer without water in the tank is **NOT COVERED BY WARRANTY**.



A. START-UP

For initial start-up, or if the brewer has not been used for an extended period of time:

- Be sure spray disk and brew gasket are properly installed in the brew head.
- Be sure the water supply is properly connected and the water supply valve is turned **ON**.
- Be sure the **WATER TANK IS FILLED**

BEFORE plugging the brewer into a receptacle, or otherwise connecting brewer to electrical power **THE WATER TANK MUST BE FILLED**. Place an empty decanter under the brew head. Lift the pour-over cover then pour warm tap water into the pour-over opening until water flows from the brew head. When water stops dripping from the brew head, empty the container.

Once the tank is full of water, connect the brewer to electrical power. The heating elements will begin heating the water in the tank. When the water has reached the proper temperature, the "READY To BREW" light will glow.

OPERATION (continued)

WATER HEATER

Water temperature is sensed by a thermobulb inserted into the water tank. This temperature signal is fed to the thermostat, which controls line power to the heating element.

The setpoint temperature is adjustable at the thermostat.

The element is protected from over-temperature by a hi-limit thermostat.

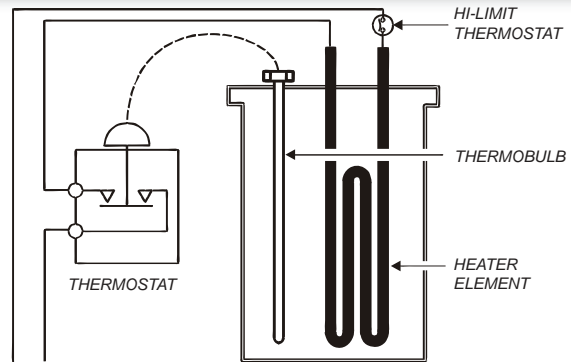

Fig. 5 Heat Control Diagram

WATER FLOW

POUR-OVER FEATURE

Pouring any amount of cold water into the pour-over opening and into the basin pan forces an identical amount of hot water out of the tank and through the spray head into the brew chamber.

AUTOMATIC OPERATION

Pressing BREW button energizes the solenoid valve, allowing water from an external water supply to flow into the basin pan and then into the hot water tank. This forces an identical amount of hot water out of the tank and through the spray head into the brew chamber.

The solenoid uses a flow control device so that flow is consistent between 20 p.s.i. and 90 p.s.i.

Length of time the solenoid is open is controlled by the timer.

HOT WATER FAUCET

The faucet water coil is submerged in the hot water tank and draws heat from the brew water. Water going to the water coil is not controlled by the solenoid valve.

The faucet is at supply water pressure any time the faucet shut-off valve is OPEN.

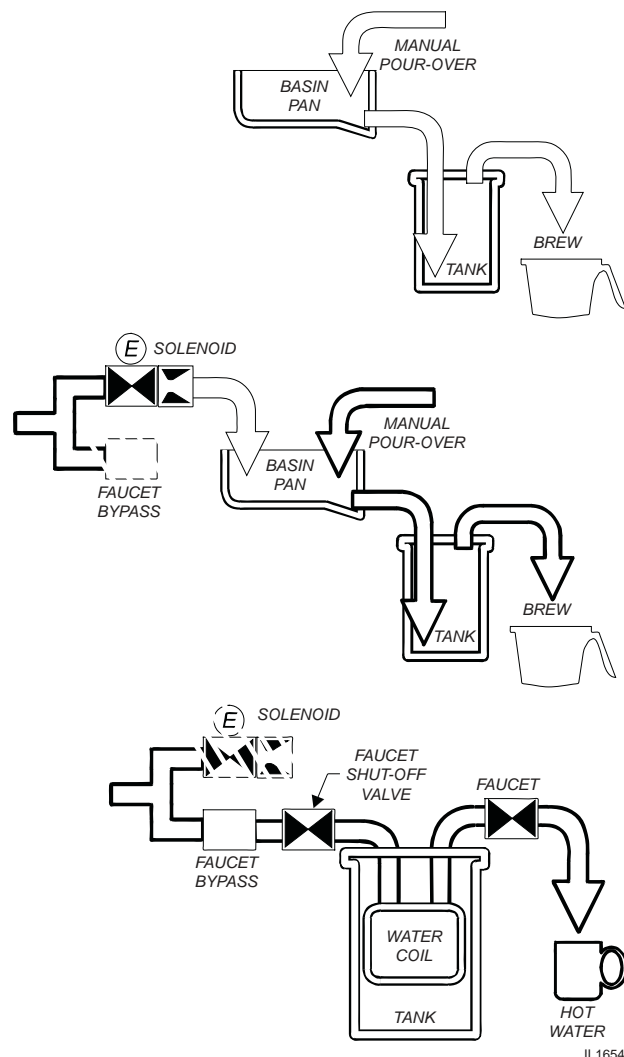

Fig. 6 Water Flow Diagram

BREWING COFFEE

CAUTION: BURN HAZARD

Exposed surfaces of the brewer, brew chamber and decanter may be HOT to the touch, and can cause serious burns.

CAUTION: BURN HAZARD

To avoid splashing or overflowing hot liquids, ALWAYS place an empty decanter under the brew chamber before starting the brew cycle. Failure to comply can cause serious burns.

CAUTION: BURN HAZARD

After a brew cycle, brew chamber contents are HOT. Remove the brew chamber and dispose of used grounds with care. Failure to comply can cause serious burns.

NOTE: Water for the hot water faucet is heated in a coil inside of the water tank. Use of the faucet will not affect the volume of water delivered for a brew. However, overuse of the faucet during a brew may lower the temperature of the brew water.

A. PREPARATION

Place one (1) genuine Bloomfield paper filter in the brew chamber. Add a pre-measured amount of fresh coffee grounds. Gently shake the brew chamber to level the bed of grounds. Slide the brew chamber into place under the brew head.

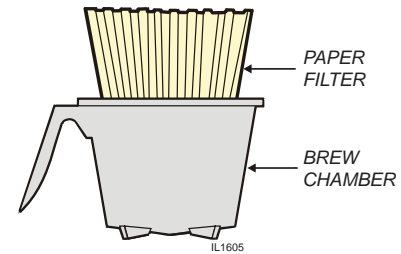

Fig. 7 Brew Chamber

B. POUR-OVER OPERATION

NOTE: Any Integrity™ brewer can be used in the pour-over mode.

BE sure "READY TO BREW" light is lit.

Place the appropriate *EMPTY* decanter in place under the brew chamber.

Fill a decanter with tap water. Lift the pour-over cover and pour the entire contents of the decanter into the pour-over opening, which will fill the basin.

Water from the basin will displace a like amount of heated water from the tank. The hot water will be forced into the brew head where it will spray over the bed of grounds. Freshly brewed coffee will begin to fill the container under the brew chamber. When the flow and all dripping stops, the coffee is ready to serve.

Discard the contents of the brew chamber. Rinse the brew chamber in a sink. When the "READY TO BREW" light glows, the brewer is ready for another brew cycle.

C. AUTOMATIC OPERATION

BE sure "READY TO BREW" light is lit.

Place an *EMPTY* decanter in place under the brew chamber.

Press the "BREW" switch. The solenoid will open for an amount of time determined by the timer setting, admitting a measured quantity of water into the basin.

Water from the basin will displace a like amount of heated water from the tank. The hot water will be forced into the brew head where it will spray over the bed of grounds. Freshly brewed coffee will begin to fill the decanter under the brew chamber. When the coffee flow and all dripping stops, the coffee is ready to serve.

Discard the contents of the brew chamber and rinse it in a sink. When the "READY TO BREW" light glows, the brewer is ready for another brew cycle.

CLEANING INSTRUCTIONS

PROCEDURE: Clean Coffee Brewer

PRECAUTIONS: Disconnect brewer from electric power.
Allow brewer to cool.

FREQUENCY: Daily

TOOLS: Mild Detergent, Clean Soft Cloth or Sponge
Bristle Brush.

1. Disconnect brewer from electric power.
Allow brewer to cool before cleaning.
2. Remove and empty decanters.
3. Remove and empty brew chamber.
4. Remove the spray disk from the brew head (See figure 8):
Press up on the spray disk ears, and then turn the disk to the left to unlatch. Remove the gasket from inside the brew head.
5. Wipe inside of brew head and area around the brew head with a soft clean cloth or sponge moistened with clean water.
6. Wash the spray disk in a sink using warm water and a mild detergent. A bristle brush may be used to clear clogged spray holes. Rinse the spray disk with clean water and allow to air dry.
7. Wash the brew chamber in a sink using warm water and a mild detergent. A bristle brush may be used to clean the inside. Rinse with clean water and allow to air dry. For stainless steel brew chambers, be sure the wire rack is properly reinstalled.
8. Wipe the exterior of the brewer with a soft clean cloth or sponge moistened with clean water.
10. Reinstall the gasket **INSIDE** the brew head, and then reinstall the spray disk.
11. Reinstall the brew chamber.
12. Decanters may be washed in a dishwasher or sink.

Procedure is complete



CAUTION: BURN HAZARD

Brewing and serving temperatures of coffee are extremely hot.
Hot coffee will cause serious skin burns.



CAUTION: SHOCK HAZARD

Do not submerge or immerse brewer in water.

IMPORTANT:

DO NOT use steel wool, sharp objects, or caustic, abrasive or chlorinated cleansers to clean the brewer.

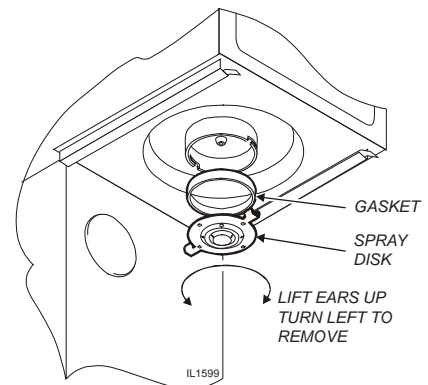

Fig. 8 Cleaning

TROUBLESHOOTING SUGGESTIONS

SYMPTOM	POSSIBLE CAUSE	SUGGESTED REMEDY
Water won't heat	Brewer unplugged or circuit breaker tripped	Check power supply cord
		Check / reset circuit breaker
	Thermostat set too low	Set for desired temperature
	Hi-Limit thermostat tripped	Allow to cool
		Reset hi-limit (8786, 8788)
	Damaged internal component or wiring	Examine wiring & connectors, thermostat and heating element, Repair/replace as needed
Pourover - no water or too little water added at startup	Be sure to add sufficient water	
Coffee level low (pour-over)	Not enough water poured in	Increase water amount
	Too much coffee grounds	Adjust amount of grounds
Coffee level too high or low (automatic)	Timer out of adjustment	Adjust timer
Brew chamber overflows	Too many filter papers or wrong filter paper	Use one (1) genuine Bloomfield filter per brew
	Brew chamber dispense hole plugged	Thoroughly clean brew chamber
	Too much coffee or too fine a grind	Adjust coffee amount and grind
Sprays water from brew head	Spray gasket improperly installed	Check/reinstall gasket on INSIDE of brew head
	Spray disk plugged	Clean spray disk
No brew (automatic)	Water supply OFF	Turn water supply ON
	Water line strainer plugged	Clean strainer (see pg. 14)
	Water filter (if used) plugged	Replace filter element
	Bad BREW switch	Replace switch
	Damaged internal component or wiring	Examine wiring & connectors, brew switch and solenoid, Repair/replace as needed
No flow from hot water faucet	Faucet valve turned OFF	Turn faucet valve ON
	Faucet plugged	Disassemble faucet, clean
Poor coffee quality	Water not hot enough	Adjust water temp 195-205°F
	Keep brewer, and decanters clean. Install a taste and odor filter in water supply, and replace cartridges regularly. Use a quality coffee with a consistent roast. Use proper grind and amount of coffee per brew.	

SERVICING INSTRUCTIONS

ACCESS PANELS

Each warmer plate has a center stud which screws into a bracket. Warmer plates on Canadian brewers are secured with a nut. Remove button plug on bottom of brewer to access nut on warmer plate. Remove warmer plates by turning counter-clockwise.

Solenoid door is held by two screws and a retaining lip.

Front Panel (In-Line Models) and Top / Rear Panel (3-Station Models):

- Remove warmer plate by turning counter-clockwise until it unscrews.
- Remove screws from two retaining clips under warmer plate.
- Lift off panel.

Front Panel (3-Station Models):

- Remove warmer plates by turning counter-clockwise until they unscrew.
- Remove screws from two retaining clips under each warmer plate.
- Remove three screws from bottom-side of front lip.
- Pull bottom of panel forward until it clears

Top Panel (All Models):

- Remove two screws from rear of top panel.
- Lift rear of panel, remove to rear.



CAUTION: SHOCK HAZARD

Opening access panels or removing warmer plates on this brew may expose uninsulated electrical components. Disconnect brewer from electrical power before removing any panel or warmer plate.

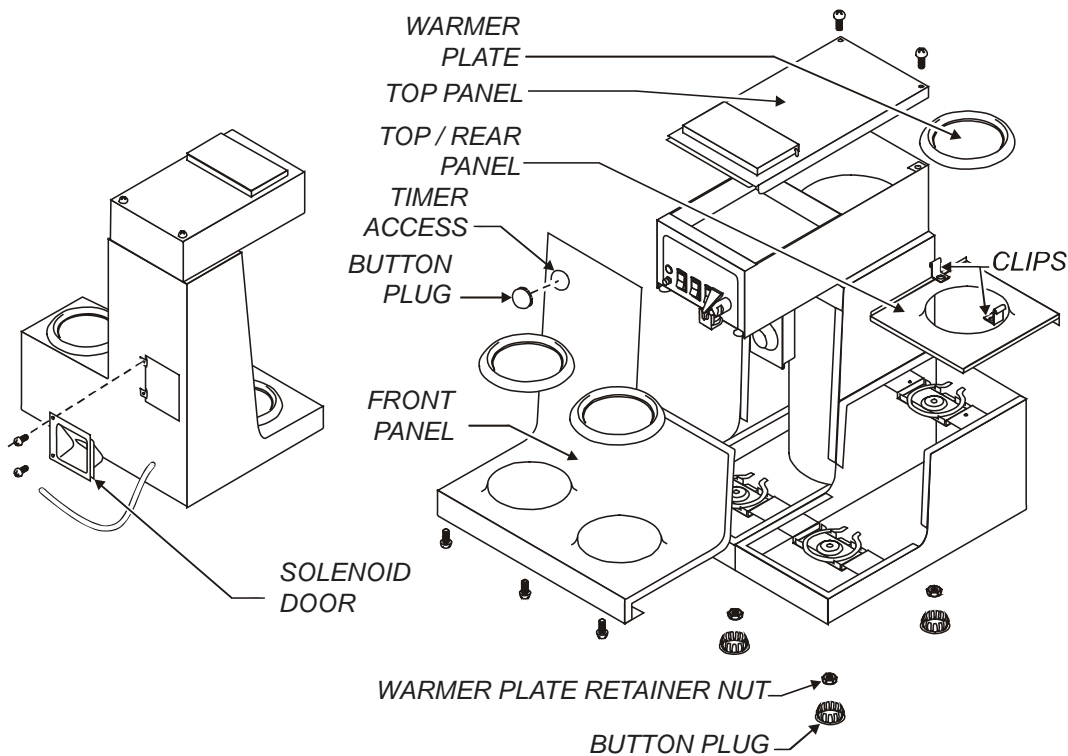

Fig. 9 Access Panels

SERVICING INSTRUCTIONS (continued)



**CAUTION:
SHOCK HAZARD**

These procedures involve exposed electrical circuits. These procedures are to be performed by qualified technical personnel only.

NOTE:

Optimum brewing temperature range is 195°F to 205°F (90°C to 96°C).

IMPORTANT:

A mechanical thermostat will maintain temperature within $\pm 5^\circ\text{F}$. To prevent boiling water in the brewer, thermostat should be adjusted to a maximum temperature equal to the local boiling temperature minus 5°F.

NOTE: 1/8 turn = approximately 10°F (5.6°C).

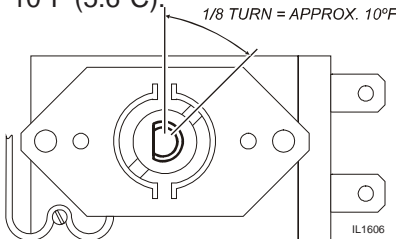

Fig. 11 Adjust Thermostat

TEMPERATURE ADJUSTMENT

Unplug power cord or turn circuit breaker OFF. Remove top panel.

Pull vent tube out of tank lid and insert a thermometer of known accuracy in vent hole. Reconnect brewer to electrical power.

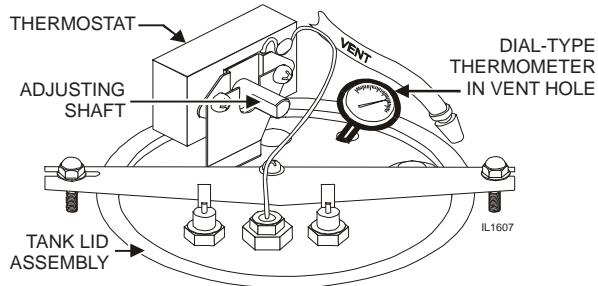

Fig. 10 Checking and Adjusting Brew Temperature

Place an empty decanter under brew chamber. Energize brewer and pour one decanter (64 oz.) of cold water into pour-over opening. When READY TO BREW light comes on, read temperature displayed on thermometer.

Adjust thermostat by turning shaft; clockwise increases temperature. 1/8 turn = approximately 10°F. Refer to Table 1 below for proper brewing temperature based on altitude.

Upon completion, remove thermometer and reinstall vent tube.

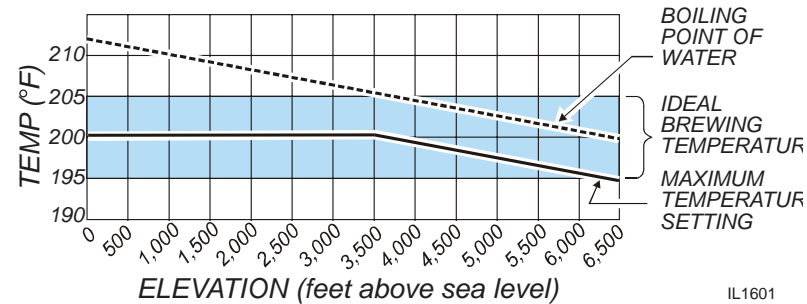
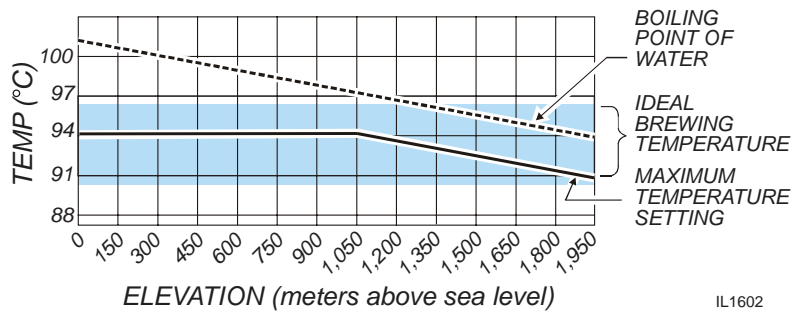

Table 1 Boiling Temperature by Altitude

SERVICING INSTRUCTIONS (continued)

TIMER ADJUSTMENT

The amount of water dispensed automatically during a brew cycle is controlled by the timer.

Place empty decanter under brew chamber. Press BREW button. Brewer should dispense one decanter of water. To adjust amount:

Remove brew chamber and button plug. Adjust knob on timer; clockwise increases time. Run several cycles to check amount of water delivered. Replace button plug.

REMOVE TANK LID ASSEMBLY

Unplug brewer or turn circuit breaker *OFF*. Turn *OFF* water supply. Remove top panel. Pull vent tube and inlet elbow out of basin pan.

Pull water inlet tube out of basin pan. Remove basin pan.

On models with faucet, disconnect inlet pipe at faucet shut-off valve and outlet pipe at faucet.

Disconnect all wiring from thermostat, hi-limit, and heating element.

Loosen center screw on tank hold-down bracket. Remove hold-down bracket by sliding short slotted end off of locking stud and lifting it off. Remove cover assembly by lifting it straight up.

Reassemble in reverse order.

REPLACE THERMOSTAT

Unplug brewer or turn circuit breaker *OFF*. Turn *OFF* water supply. Remove top panel.

Disconnect all wiring from thermostat only. Loosen and free jam nut from pass-thru fitting securing temperature sensing bulb. Remove two screws holding thermostat to bracket.

Lift out thermostat, sensing bulb and thermostat gasket.

Push sensing bulb into tank lid thermowell until fitting seats. Tighten capillary lock nut only enough to ensure no water leakage. Excessive tightening is not necessary.

Reassemble in reverse order.

IMPORTANT: Water pressure must be between 20 p.s.i and 90 p.s.i. flowing pressure. If water pressure exceeds this value, or if water pressure varies greatly, a pressure regulator must be installed in the water supply line.

IMPORTANT: Before setting assembly into tank, make sure tank lid gasket is properly seated on flange of lid. *DO NOT OVER-TIGHTEN.*

IMPORTANT: If mounting thermostat p/n 8512-51, be sure to place a new seal washer below the fitting on the capillary line.

If replacing gray-bodied thermo with p/n 8512-51, be sure to remove tube from thermowell.

SERVICING INSTRUCTIONS (continued)

IMPORTANT: When replacing heating element, also replace seal gaskets.

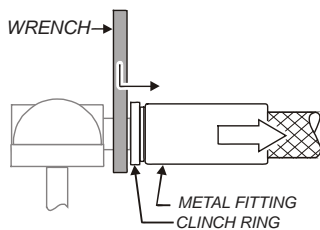
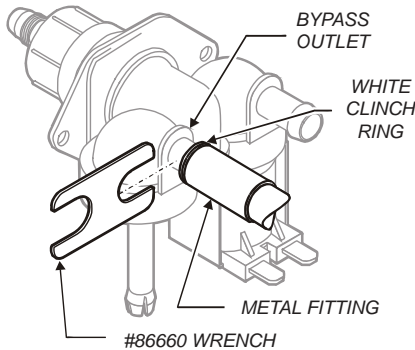

SLIDE WRENCH BETWEEN VALVE AND HOSE FITTING
PRESS CLINCH RING TOWARD METAL FITTING TO RELEASE
IL1699

Fig. 11 Remove Faucet Supply from Solenoid

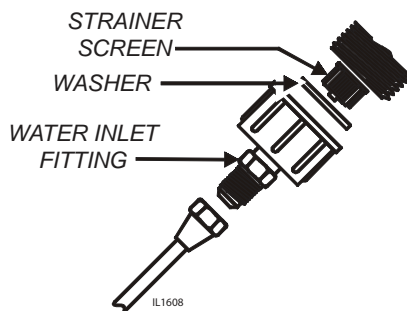

Fig. 12 Clean Strainer Screen

REPLACE HEATING ELEMENT

Remove tank lid assembly as described on page 13.

Remove two hex nuts holding element to cover. Pull element from mounting holes.

Reassemble in reverse order.

REPLACE SOLENOID

Symptom: Automatic brewer will not flow water; or, automatic brewer drips continuously from brew head.

NOTE: Wrench p/n 86660 is designed to allow easy removal of the hoses from the plastic solenoid valve.

IMPORTANT: Shut-off water and electric supply to brewer before removing hoses or wiring.

Remove water supply flare fitting:

- Slide the 5/8" end of the wrench over the flats on the inlet fitting of the valve.
- Hold the wrench to prevent the inlet fitting from turning while installing or removing the inlet water supply flare nut.

Remove braided hose:

- Slide the 7/16" end of the wrench between the valve body and the white ring on the extreme end of the metal hose fitting.
- Pressure on the white ring toward the metal ferrule releases the clinch ring, allowing the hose to be easily slid off of the solenoid bypass outlet.
- Install hose on new valve by pressing end of hose onto bypass outlet until it is fully seated.

Disconnect wiring.

Remove two screws holding solenoid to access door.

Reassemble in reverse order.

CLEAN SOLENOID SCREEN

Symptom: Automatic brewer will not flow water.

Unplug power cord or turn circuit breaker *OFF*. Turn *OFF* and disconnect water supply from brewer inlet fitting.

Unscrew water inlet fitting from solenoid.

Using needle-nose pliers, withdraw strainer screen from solenoid. Clean screen under faucet. A stiff bristle brush may be used if necessary.

Reinsert screen in solenoid. Be careful to maintain correct orientation. (The *OPEN END* of the screen goes in *FIRST*.)

Reassemble in reverse order.

SERVICING INSTRUCTIONS (continued)

REPLACE TIMER ASSEMBLY

Unplug power cord or turn circuit breaker OFF.

Remove front panel. Remove knob and three screws holding timer to bracket. Disconnect wiring to timer.

Reassemble in reverse order.

Adjust timer as described on page 13

REPLACE HOT WATER FAUCET COIL

Symptom: Brewer drips continuously from brew head, except when faucet valve is turned OFF.

Remove tank lid assembly per above.

Remove two hex nuts hot water coil to cover. Pull coil from mounting holes.

Reassemble in reverse order.

REPAIR HOT WATER FAUCET

Remove top panel and turn faucet valve OFF.

Unscrew aerator cap from faucet and remove handle retaining clip. Do not let faucet body turn.

Pull bonnet assembly from faucet body.

Examine the interior of the faucet body and the surface of the seat cup. Clean out any debris in the faucet body, using a stiff bristle brush if necessary.

Examine the aerator. Clean any debris from the screen or flow straightener, using a stiff bristle brush if necessary.

Reassemble in reverse order.

REPLACE BREW READY LIGHT or BREW BUTTON

Unplug power cord or turn circuit breaker OFF.

Using Switch Removal Tool (p/n 83209) or a thin screwdriver, pry light or switch from mounting hole. Disconnect leads.

Reassemble in reverse order.

IMPORTANT: When replacing water faucet coil, also replace seal gaskets.

NOTE: Any abrasion or roughness on the flat end of the seat cup will require replacing the seat cup:

Work the seat cup out of the bonnet and off of the end of the stem.

Install a new seat cup, making sure the knob on the stem is fully inserted into the pocket of the seat cup, and the skirt of the seat cup is fully inserted into the bonnet.

SERVICING INSTRUCTIONS (continued)



CAUTION: CHEMICAL BURN HAZARD

Deliming chemicals are caustic. Wear appropriate protective gloves and goggles during this procedure.

Never siphon deliming chemicals or solutions by mouth.

This operation should only be performed by qualified and experienced service personnel.

PROCEDURE: Delime the Water Tank

PRECAUTIONS: Disconnect brewer from electric power.
Allow brewer to cool.

FREQUENCY: As required (Brewer slow to heat)

TOOLS: Deliming Solution
Protective Gloves, Goggles & Apron
Mild Detergent, Clean Soft Cloth or Sponge
Bristle Brush, Bottle Brush
Large Sink (or other appropriate work area)

IMPORTANT: DO NOT spill, splash or pour water or deliming solution into or over any internal component other than the inside of the water tank.

IMPORTANT: DO NOT allow any internal components to come into contact with the deliming solution. Take care to keep all internal components dry.

NOTE: Repeat steps 4 thru 5 as required to remove all scale and lime build-up.

NOTE: Normally, silicone hoses do not need to be delimed. Should deliming hoses become necessary, Bloomfield recommends replacing the hoses.

1. Disconnect brewer from the electrical supply. Turn off the water shut-off valve and disconnect the water supply line from the brewer inlet fitting.
2. Remove the tank lid assembly as described on page 13.
3. Remove the water tank from the brewer body by lifting straight up. Empty all water from the tank. Set the tank back into the brewer.
4. Mix 2 quarts of deliming solution according to the manufacturer's directions. Carefully pour the deliming solution into the water tank. Lower the lid assembly back onto the tank. Allow to sit for 30 minutes, or as directed by the manufacturer.
5. At end of soaking period, remove lid assembly from tank. Thoroughly rinse internal components of lid assembly with clear water. Using a stiff bristle brush, scrub the heating element (and faucet water coil on automatic brewers) to remove lime and calcium build-up. Rinse with clean water. Store lid assembly in a safe location.
6. Remove the tank from the brewer and empty. Using a stiff bristle brush, scrub the interior of the water tank to remove lime and calcium build-up. Rinse with clean water.
7. Set the tank back into the brewer. Reassemble the tank lid to the water tank. Make sure the gasket is properly in place, and then reinstall the hold-down strap.
8. Reinstall wiring to heating element and thermostat. Reinstall the hi-limit thermostat (if removed). For brewers with hot water faucet, reassemble faucet piping. Verify that all internal components are dry, then reinstall the top panel.
9. Reconnect brewer to electrical supply and, for automatic brewers, reconnect water supply.
10. Install the brew chamber without filter paper or grounds. Run at least three full brew cycles and discard all water generated.
11. Brewer is ready to use.

Koffee-King™ EXPLODED VIEW & PARTS LIST

CABINET & RELATED COMPONENTS

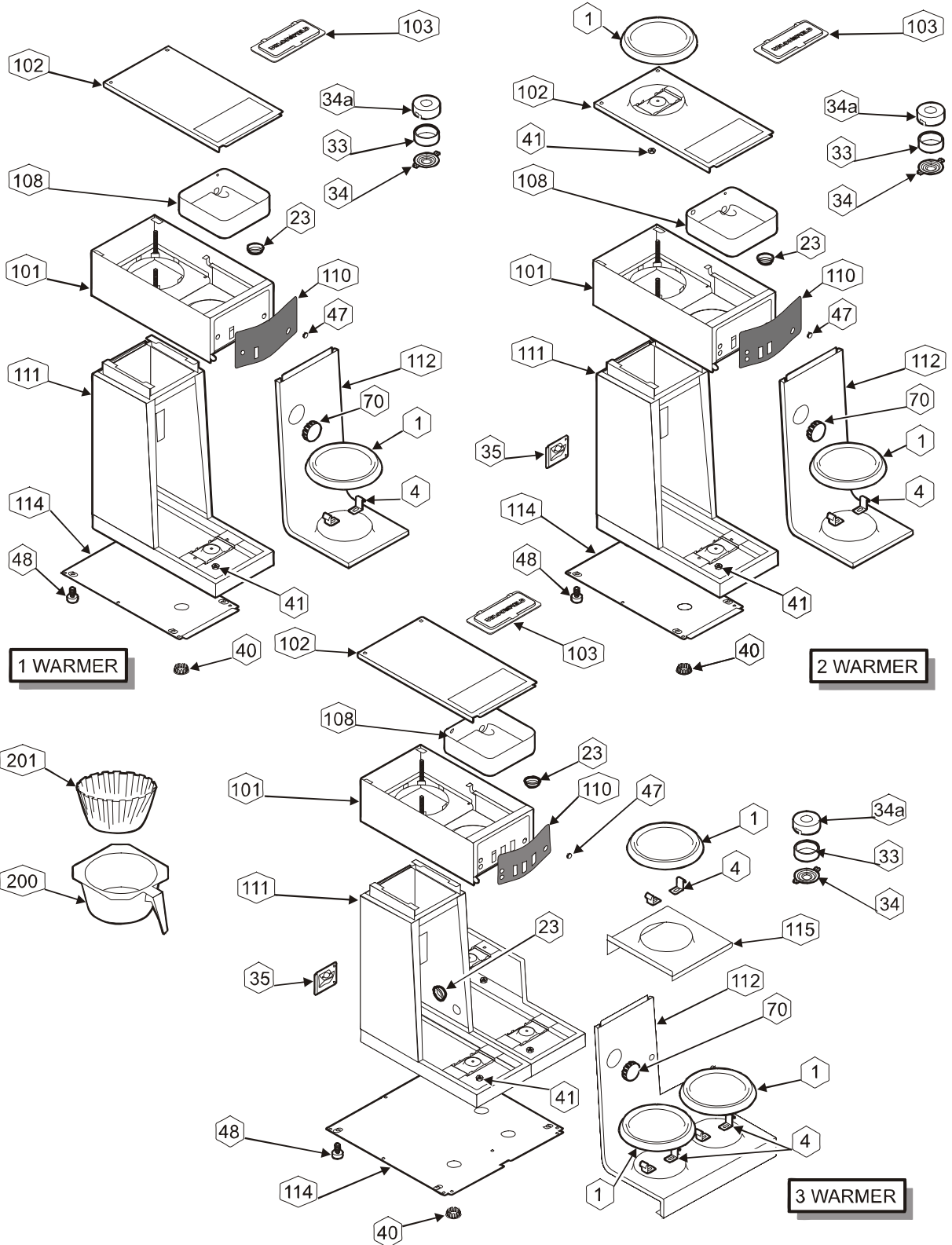

2M-75804-611 Koffee-King 8900 Series Brewer

Koffee-King™ EXPLODED VIEW & PARTS LIST (continued)

ITEM	PART NO.	DESCRIPTION	USED ON
1	2D-70090	COVER PLATE, WARMER, BLACK, 1/4-28 STUD	ALL, MADE IN USA
	2D-Z15630	PLATE COVER WARMER, 1/4-20 STUD	ALL, MADE IN CHINA
4	2C-70098	CLIP, PANEL RETAINING	ALL
20	2C-70132	NUT, #8SMS, TINNERMAN (not shown)	ALL
23	2K-70229	BUSHING, HEYCO	ALL
33	2I-70139	GASKET, SPRAY HEAD	ALL
34	A6-72727	SPRAY DISK, EMBOSSED	ALL
34a	A6-70163	RETAINER, SPRAY HEAD (REQUIRES DRILL/RIVETS TO INSTALL)	ALL
35	2Q-75089	DOOR, SOLENOID ACCESS, PLASTIC	8540, -72, -73
40	2P-70953	BUTTON PLUG, 1-1/8" DIA, METAL (WARMER PLATE RETAINER)	ALL (Canadian)
41	18-50	NUT, WARMER PLATE RETAINING, 1/4-28	ALL (Canadian)
47	2P-70272	BUTTON PLUG, 1/2" DIA, PLASTIC (NON FAUCET MODELS)	8542, -43, -71, -73
48	2A-71732	ASSEMBLY, ADJUSTABLE LEG	ALL
70	2P-70053	BUTTON PLUG, 2" DIA, METAL (TIMER)	8540, -71, -72, -73
101	A6-70231	ASSEMBLY, BASIN TOP	ALL
102	WS-8512-56	BASIN COVER W/WARMER MOUNT	8540, 8543
	WS-8542-6	BASIN COVER, W/O WARMER MOUNT	8542, -71, -72, -73
103	2F-76666	ASSEMBLY, POUR-OVER PLASTIC	ALL
108	2D-70095	BASIN PAN (AUTOMATIC)	8540, -72, -73
	2D-70226	BASIN PAN (POUR-OVER)	8542, 8543, 8571
110	2M-71135	LABEL, CONTROL PANEL DECAL (IN-LINE POUR-OVER 1W)	8542
	2M-70252	LABEL, CONTROL PANEL DECAL (IN-LINE POUR-OVER 2W)	8543
	2M-70289	LABEL, CONTROL PANEL DECAL (IN-LINE AUTOMATIC 2W)	8540
	2M-70279	LABEL, CONTROL PANEL DECAL (STEP-UP AUTOMATIC 3W)	8572, 8573
	2M-70264	LABEL, CONTROL PANEL DECAL (STEP-UP POUR-OVER 3W)	8571
111	B7-70249	ASSEMBLY, BREWER BASE (IN-LINE POUR-OVER)	8542, 8543
	DD-8540-25	ASSEMBLY, BREWER BASE (IN-LINE AUTOMATIC)	8540
	67-70263	ASSEMBLY, BREWER BASE (STEP-UP POUR-OVER)	8571
	DD-8572-33	ASSEMBLY, BREWER BASE (STEP-UP AUTOMATIC)	8572, 8573
	NONE	ASSEMBLY, BREWER BASE (STEP-UP AUTOMATIC)	
112	A6-70288	PANEL, FRONT (IN-LINE AUTOMATIC)	8540
	A6-70227	PANEL, FRONT (IN-LINE POUR-OVER)	8542, 8543
	B7-70265	PANEL, FRONT (STEP-UP POUR-OVER)	8571
	A6-8572-10	PANEL, FRONT (STEP-UP AUTOMATIC)	8572, 8573
114	A6-70256	PLATE BOT 1-2 WRMR S/SAAY	8430, 8540, 8718, 8730, 8738, 8783
	A6-71550	PLATE BOT SUB ASSY AIRPOT	8773, 8774
	A6-70269	PLATE BOT 3-WRMR SUB ASSY	8571, 8572, 8573
115	A6-70267	PANEL, COVER W/WARMER MOUNT	8571, 8572, 8573
200	2D-70234	BREW CHAMBER, BLACK PLASTIC	
	WS-8942-6	BREW CHAMBER, BROWN PLASTIC (OPTIONAL limited to stock on hand)	ALL
	2D-70114	BREW CHAMBER, STAINLESS W/ WIRE BASKET (OPTIONAL)	
201	WS-POF	FILTER PAPER, COFFEE (CASE OF 1000)	ALL

2M-75804-611 Koffee-King 8900 Series Brewer

Koffee-King™ EXPLODED VIEW & PARTS LIST (continued)

HOT WATER TANK ASSEMBLY

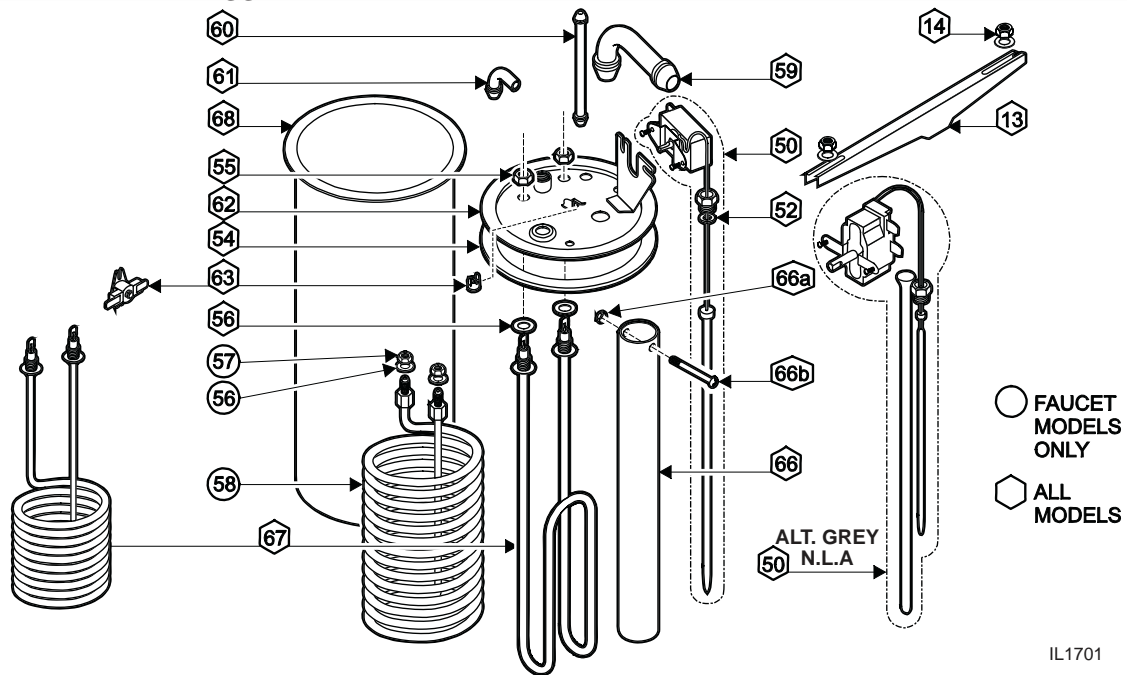

IL1701

ITEM	PART NO.	DESCRIPTION	USED ON
13	2C-70134	HOLD-DOWN STRAP	ALL
14	2C-73457	NUT, HEX 8-32 KEPS	ALL
50	WS-8512-51	THERMOSTAT (BLACK BODY - INCL. SEAL & MOUNTING SCREWS)	ALL
	N.L.A	THERMO (ALT) (GRAY BODY - INCL. TUBE & MOUNTING SCREWS)	
52	2C-70174	SEAL WASHER, THERMO CAP TUBE (ONLY)	ALL
54	2I-70147	TANK COVER GASKET	ALL
55	2C-70175	NUT HEX 1/2-20 BRASS	ALL
56	2I-70152	SEAL GASKET, ELEMENT OR WATER COIL	ALL
57	2C-70151	NUT HEX 7/16-20 BRASS	8540, 8572
58	2N-70149	HOT WATER COIL	8540, 8572
59	2K-70101	TUBE, BASIN OUTLET/TANK INLET, SILICONE	ALL
60	2V-70102	TUBE, VENT, SILICONE	ALL
61	2K-70103	ELBOW, TANK OUTLET, SILICONE	ALL
62	A6-70221	TAN COVER, PLATE ONLY, 6 HOLES	8542, 8543, 8571, 8573
	A6-70142	TAN COVER, PLATE ONLY, 8 HOLES	8540, 8572
63	2T-47499	THERMOSTAT, HI-LIMIT	ALL
66	2V-70144	WATER INLET TUBE	ALL
66a	2C-70146	NUT, HEX 4-40 SS	ALL
66b	2C-70145	SCREW 4-40 x 1 PAN HEAD	ALL
67	2N-70167UL	HEATING ELEMENT (120V, 1200W)	ALL Canadian
	2N-70143UL	HEATING ELEMENT (120V, 1500W)	ALL, exc. Canadian
	2N-70173UL	HEATING ELEMENT (240V, 1800W)	UK & EU, 230V UNITS
68	2D-70110	TANK BODY	ALL

TANK COVER ASSEMBLY

WS-8541WF-300	INCLUDES: MOUNTED THERMO, HI-LIMIT, 120V 1500W HEATING ELEMENT & HOT WATER COIL)
WS-8543-300	INCLUDES: MOUNTED THERMO, HI-LIMIT, 120V 1500W HEATING ELEMENT. NO HOT WATER COIL)

2M-75804-611 Koffee-King 8900 Series Brewer

Koffee-King™ EXPLODED VIEW & PARTS LIST (continued)

INTERNAL PLUMBING COMPONENTS

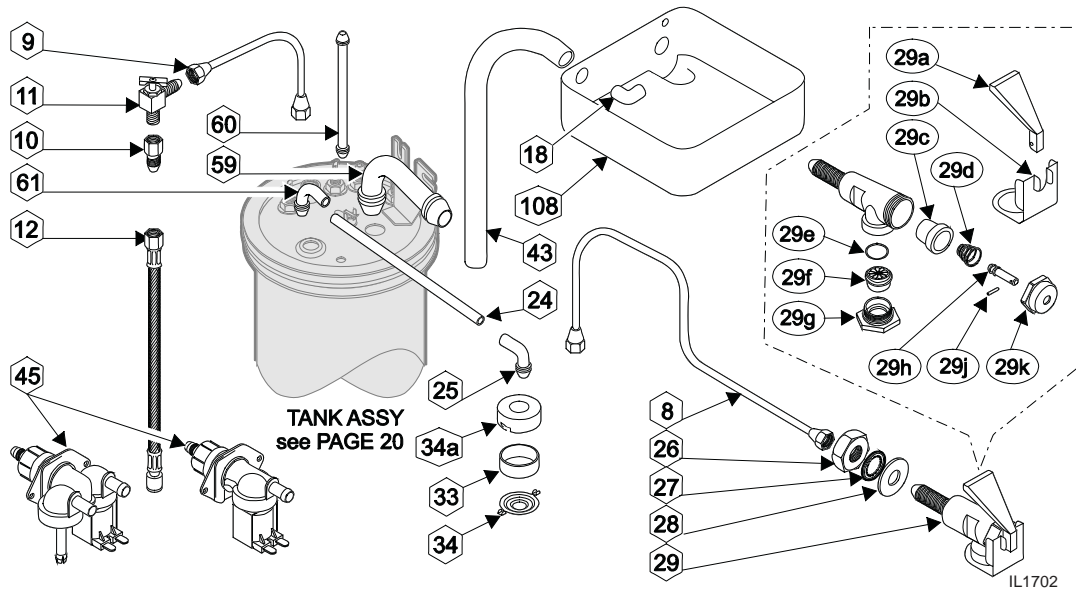

ITEM	PART NO.	DESCRIPTION	USED ON
8	2V-70104	FORMED TUBE, FAUCET OUTLET ASSEMBLY 10-7/8" LONG	8540, 8572
9	2V-70111	FORMED TUBE, FAUCET COIL INLET ASSEMBLY	8540, 8572
10	2E-70451	ADAPTER, 1/4" MALE FLARE x 1/8" FPT BRASS	8540, 8572
11	2V-70352	VALVE, FAUCET SHUT OFF, NEEDLE SEAT	8540, 8572
12	2J-75681	BRAIDED TUBE, FAUCET INLET 6MM x 299MM (11-3/4") LONG	8540, 8572
18	2K-70096	ELBOW, BASIN INLET DIVERTER POLYPROPYLENE	8540, -72, -73
24	2V-70131	TUBE, BREW OUTLET, METAL 4-3/4" LONG	ALL
25	2K-70130	ELBOW, SPRAYER, SILICONE	ALL
26	2C-72680	LOCK NUT, HEX 7-16-20	8540, 8572
27	2C-70107	LOCK WASHER 7/16" EXT SEMS (FAUCET)	8540, 8572
28	2C-72681	WASHER, FLAT 15/32" x 1-1/8" x 1/16" SS	8540, 8572
29	WS-82556	FAUCET ASSEMBLY, PRESSURE	8540, 8572
33	2I-70139	GASKET, SPRAY HEAD	ALL
34	A6-72727	SPRAY DISK, EMBOSSED	ALL
34a	A6-70163	RETAINER, SPRAY HEAD (REQUIRES DRILL/RIVETS TO INSTALL)	ALL
43	A6-70276	TUBE, BASIN INLET, SILICONE 13"	8540, -72, -73
45	2E-73612	SOLENOID, SINGLE, 120V, .75 GPM	8573
	2E-75685	SOLENOID W/BYPASS, 120V, .75 GPM	8540, 8572
	2E-Z16608	SOLENOID W/BYPASS, 120V, .30 GPM	8540D2F, 8572D3F
	2E-75760	SOLENOID SINGLE 220/240V	UK & EU 230V UNITS
	2V-70124	VALVE SOLENOID 120V, METAL, .75GPM	
59	2K-70101	TUBE, BASIN OUTLET/TANK INLET, SILICONE	ALL
60	2V-70102	TUBE, VENT, SILICONE	ALL
61	2K-70103	ELBOW, TANK OUTLET, SILICONE	ALL
108	2D-70095	BASIN PAN (AUTOMATIC)	8540, -72, -73
	2D-70226	BASIN PAN (POUR-OVER)	8542, 8543, 8571

FAUCET REPAIR KITS	
WS-82573	HANDLE, FAUCET RED (29a)
WS-82575	SEAT CUP (29c)
WS-82576	FAUCET REPAIR KIT, INCL: HANDLE (29a), SEAT CUP (29c), SPRING (29d), STEM (29h), PIN (29j) & BONNET (29k)
WS-82682	RETAINER CLIP (29b)
WS-84804	AERATOR REPLACEMENT, INCL: O-RING (29e), DISK (29f) & CAP (29g)
WS-84870	AERATOR REPAIR KIT, INCL: O-RING (29e) & DISK (29f)

Koffee-King™ EXPLODED VIEW & PARTS LIST (continued)

ELECTRICAL COMPONENTS

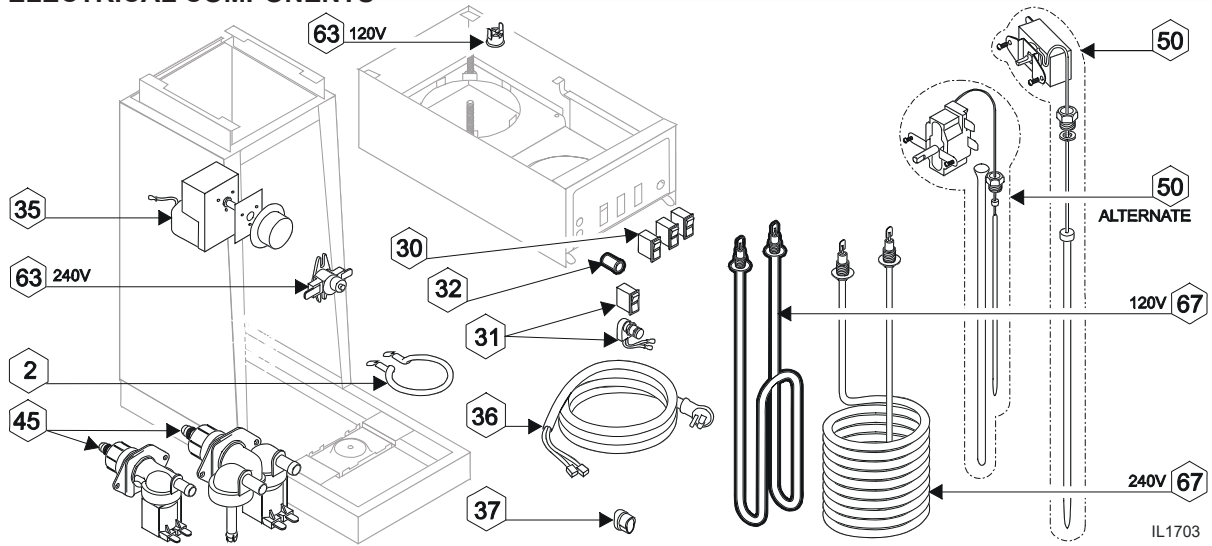

ITEM	PART NO.	DESCRIPTION	USED ON
2	2N-70091UL	HEATING ELEMENT, WARMER 120V 100W	ALL
	2N-70635UL	ELEM WMR, 100W @240/85W @220	UK & EU 230V UNITS
30	2E-72946	SWITCH, WARMER ON/OFF 120V	ALL
	2E-70247	SWITCH ON OFF LTD BLACK	UK & EU 230V UNITS
31	2E-70137	SWITCH, MOMENTARY PUSH-BUTTON, BREW	8572, 8573
	2E-70733	SWITCH, MOMENTARY ROCKER, BREW	8540
32	2J-72671	INDICATOR, 120V, READY-TO-BREW	ALL
	2J-70644	LIGHT PILOT GREEN 250V	UK & EU 230V UNITS
35	2P-Z16730	TIMER, 3 MIN, 120V	8540, -72, -73
	2P-70054RO	TIMER W/KNOB 2-MIN 240V	UK & EU 230V UNITS
36	2E-70353	POWER CORD ASSEMBLY, 120V NEMA 5-15P	ALL
	A6-WL0139	CORD & UK PLUG ASSY. TERM	UK 230V UNITS
	A6-71156	CORD CAP ASSY EURO	EU 230V UNITS
37	2K-70215	STRAIN RELIEF	ALL
	2kk-70648	STRAIN RELIEF SMALL	UK & EU 230V UNITS
45	2E-73612	SOLENOID, SINGLE, 120V, .75 GPM	8573
	2E-75760	SOLENOID SINGLE, 220/240V	UK & EU 230V UNITS
	2E-75685	SOLENOID W/BYPASS, 120V, .75 GPM	8540, 8572
	2E-Z16608	SOLENOID W/BYPASS, 120V, .30 GPM	8540D2F, 8572D3F
	2E-74570	SOLENOID W/BYPASS, 240V, 75GPM	UK & EU 230V UNITS
50	WS-8512-51	THERMOSTAT (BLACK BODY - INCL. SEAL & MOUNTING SCREWS)	ALL
63	2T-47499	THERMO, HI-LIMIT	ALL
67	2N-70167UL	HEATING ELEMENT (120V, 1200W)	ALL Canadian
	2N-70143UL	HEATING ELEMENT (120V, 1500W)	ALL, exc. Canadian
	2N-70173UL	HEATING ELEMENT (240V, 1800W)	UK & EU 230V UNITS

SOLENOID REPAIR KITS

WS-85218	INLET FITTING KIT INCLUDES: CAP (45a), FITTING (45b), GASKET (45c) & STRAINER (45d)
WS-85219	INLET STRAINER (45d ONLY)

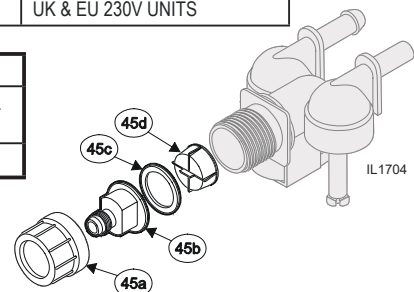

2M-75804-611 Koffee-King 8900 Series Brewer

Koffee-King™ WIRING DIAGRAMS

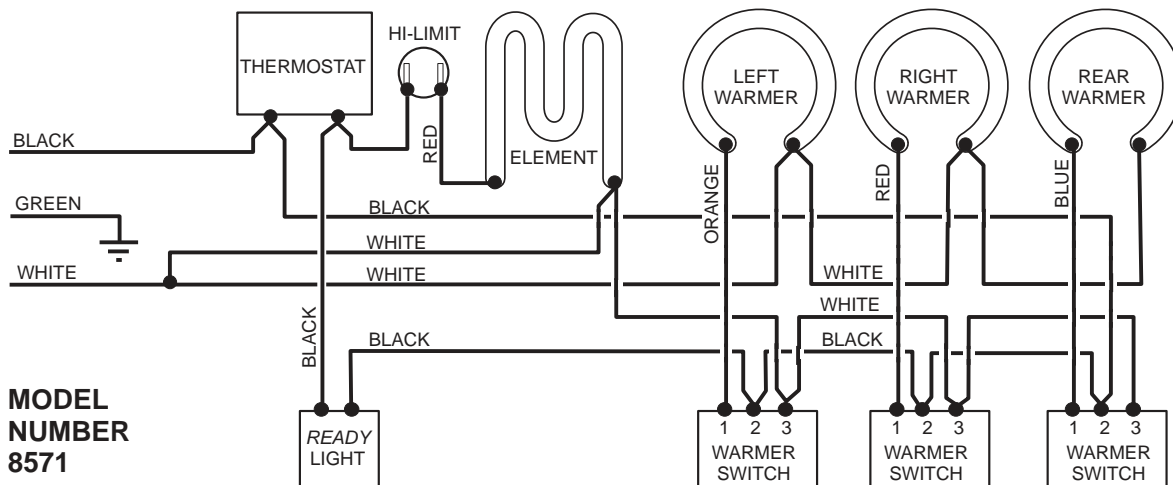
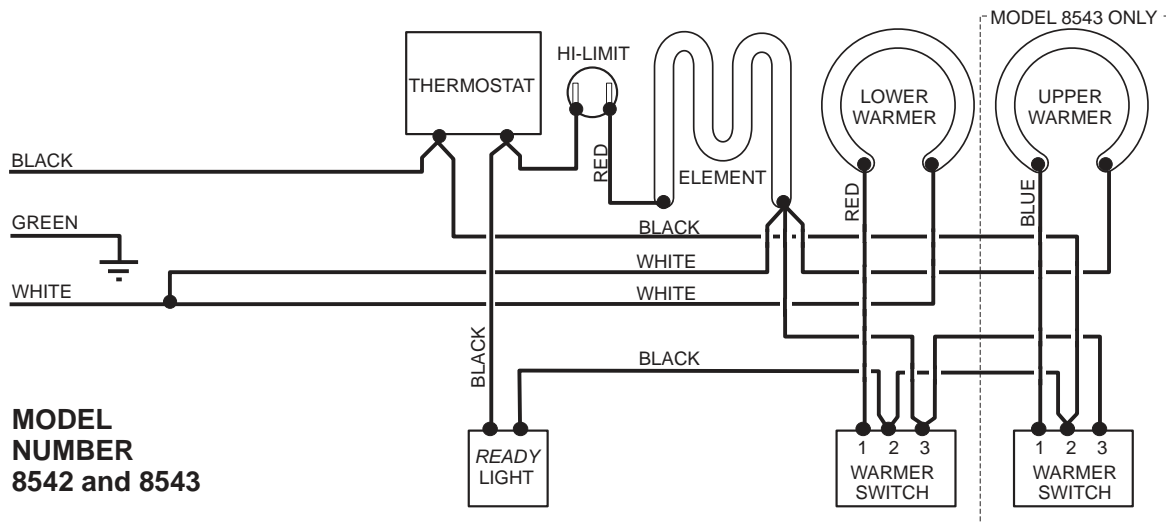
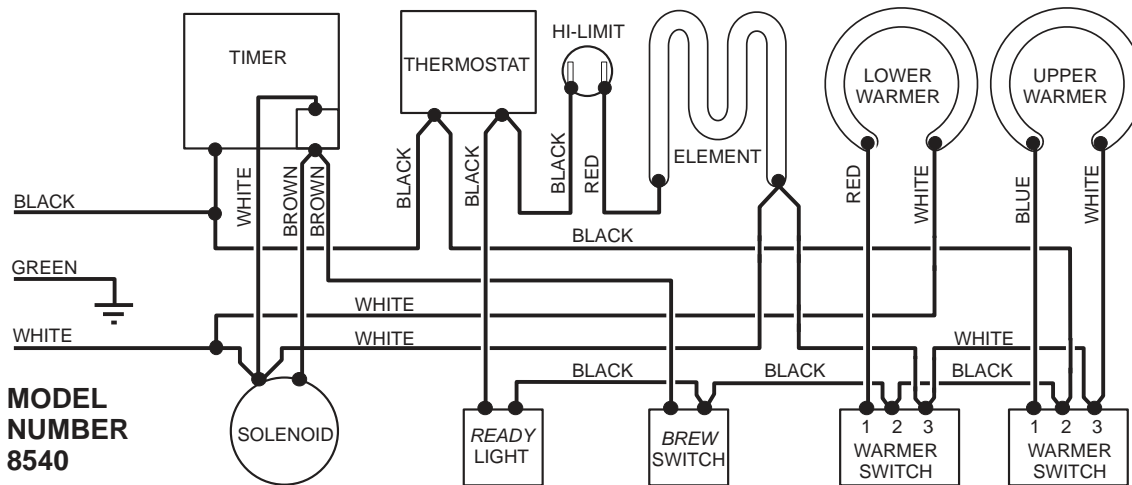

Koffee-King™ WIRING DIAGRAMS (continued)

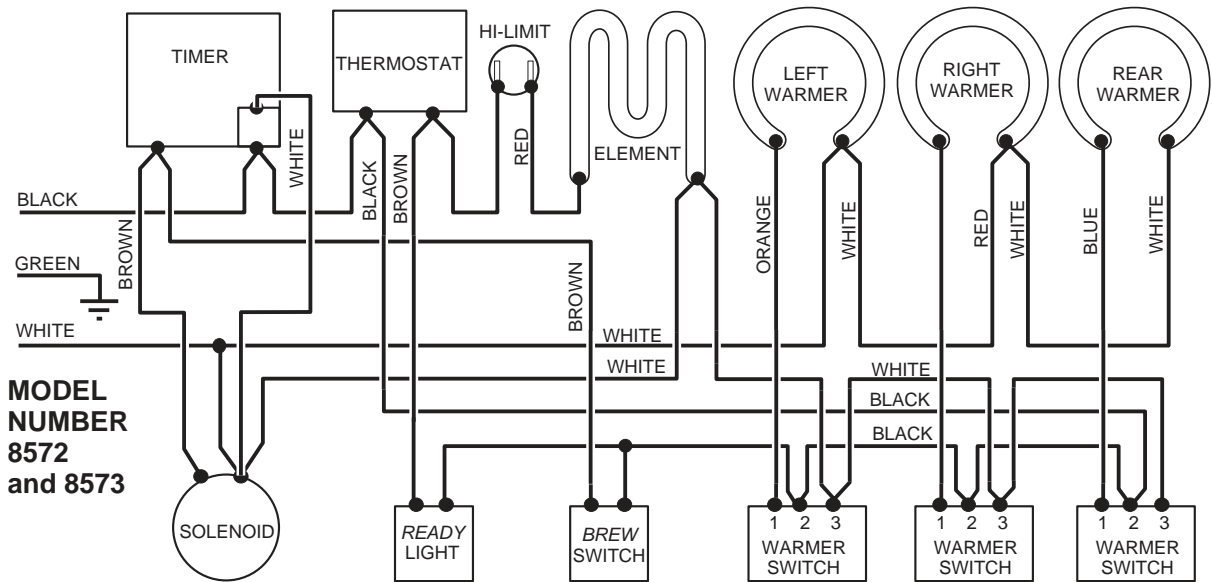

NOTES:

2M-75804-611 Koffee-King 8900 Series Brewer

NOTES:

2M-75804-611 Koffee-King 8900 Series Brewer



2060 Cessna Dr, Suite 100
Vacaville, CA 95688
phone (707)448-5151 fax (707)448-1521
www.bloomfieldworldwide.com

Wunder-Bar™